



# Sarasota Flying Wood Chips Newsletter

Volume 1 Issue 12

December 2018

**December Greetings to everyone,** and with each meeting and issue of the newsletter I am saying this to more members, both new, and returning. It's great to see our growth.

Thank you again to everyone who came to Advantage Lumber on December 1st for the **Tool Exchange and Lumber Sale**. Our friends at Advantage went all out with both the variety and pricing of their sale items. Judging by the steady stream of traffic through the place, I would say many others thought so too. They are planning to do another sale on Saturday, January 5th. We will supply you with details on that one. It will be a busy day for our club, as that evening we have our annual banquet.

*Holiday banquet:* as of a few days ago we had about 40 signed up. I recommend signing up soon if you wish to attend. Please text **Alan Levin** at 941-456-9500 to let him know your coming. Be sure you include your name, number in your party, and food preferences—fish, chicken, or beef. Attendees do not have to be club members. Don't hesitate to include spouses, significant others, friends, or out-of-town holiday guests who are still hanging around. Please bring contributions to both the silent and live auction, as well as something for the instant gallery to show non-members what we create in our club. We have a lot of talent to share.

*Upcoming dates to remember:* January 4th is the deadline for entry forms for the **Punta Gorda Show** ([www.flwoodartexpo.com](http://www.flwoodartexpo.com)). The deadline for entry forms for the **Tampa State Fair Competition** is December 14, even though the Fair isn't until February. Details at

[www.floridastatefair.com/p/about](http://www.floridastatefair.com/p/about). If you have an entry for the Fair, it entitles you to a free ticket to the Woodworking Show. ([www.thewoodworkingshows.com/tampa.html](http://www.thewoodworkingshows.com/tampa.html)). Finally, the **Florida Woodturning Symposium** ([floridawoodturningsymposium.com/registration/](http://floridawoodturningsymposium.com/registration/)), February 8th-10th, is still accepting registrations.

I am excited about our upcoming demo and workshop with **Janet Collins** on December 19th & 20th. We would like to have eight participants in the workshop, but could stretch it to ten if needed. For \$35 you will get a bowl blank, lunch, and lots of instruction in inlay techniques, something for which she has become very well-known. Her biography is on page three of this newsletter.

Our friends at **All Faiths Food Bank** ([www.allfaithsfoodbank.org](http://www.allfaithsfoodbank.org)) were sooooo appreciative of our bowl donations for their big "Bowls of Hope" fund drive. We even got a plug on the front page of the November 29 edition of the "**Sarasota Observer**". When I spoke to our liaison at the Food Bank, she said they had exceeded their fund objectives. Thanks to all of you who contributed to this effort Keep on turning! We have agreed to do it again next year. Blanks will continue to be available at Franck's studio.

I have orders for three monogrammed shirts. When I get up to five, I will submit the order. See me at a meeting, or send an email, if you want one. Be sure to include the size.

Thanks!

**Russ Fellows**  
President ([Skunkmen@gmail.com](mailto:Skunkmen@gmail.com))

## Upcoming 2018 Sarasota Woodturners Events and Demos

**Janet A. Collins at Advantage Lumber  
December 19, 2018**



**Green Mountain Woodturning & Furniture Making**  
Janet A. Collins, Woodturner/Furniture Maker

Woodturning Gallery

Home  
About the Artist  
Woodturning Gallery  
Furniture Gallery  
Contact

Follow us on 

P.O. Box 353  
134 South Bayley Hazen Rd.  
Ryegate, VT 05042  
802-584-4341 or 339-206-5268  
curfyacer@gmail.com

To see what items are available and to purchase, please visit my Etsy shop at [www.Etsy.com/shop/birdseyem](http://www.Etsy.com/shop/birdseyem)



11.25d x 4.75d Spalted Maple



12 sq x 2.75d Tiger Maple



14d x 5d Cherry with black veneer inlay



9d x 8d Claro Walnut



14.75d x 2.75d Mahogany



14d x 2d Walnut platter with Hot Sand Stained Inlay



7d x 6.5d Maple Burl



8.5d x 1d Tiger Maple



3d x 4d Mahogany w/Picasso Marble cabochon



7.5d x 4d Walnut with textured rim



12 d x 1.5d Mahogany Bowl with Line & Berry Inlay



6.25d x 2.25d Maple



6.5d x 2.5d Curly Ash

Bottle Stoppers- various wood

## Upcoming 2019 Sarasota Woodturners Events and Demos

**Dave Buchholz at Advantage Lumber  
January 19, 2019.**

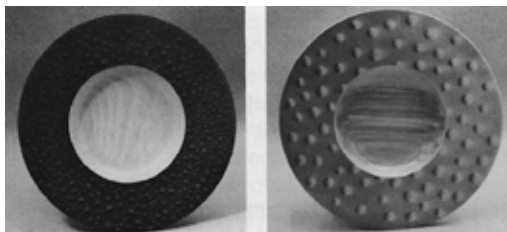

**Walter Wager at Advantage Lumber  
February 20, 2019**



**\* Hardwood Blowout Sale! \***  
**Advantage Lumber** on Saturday January 5  
8 a.m. - 3 p.m.

### In This Issue

- 9** Bill Clark's "Pearls & Ideas" Demo.
- 12** Russ Fellows' German Ring Turning Demo.
- 18** Franck Johannesen's Genie Bowl Hollowing Demo.
- 24** Jim Weeks' Bandsaw Discussion.

**"We are dedicated to promoting the art of woodturning through educational demonstrations and hands-on training. We meet to share our techniques, methods and skills. We provide assistance with tool and equipment recommendations."**

### Sarasota Woodturner's Club Officers

- President - Russ Fellows**  
email: [skunkmen@gmail.com](mailto:skunkmen@gmail.com)
- Vice President - Jim Weeks**  
email: [jburtonweeks@gmail.com](mailto:jburtonweeks@gmail.com)
- Treasurer - Stephen Johns**  
email: [steve2515@hotmail.com](mailto:steve2515@hotmail.com)
- Secretary - Dave Hausmann**  
email: [dhausmann@comcast.net](mailto:dhausmann@comcast.net)  
phone 703-608-4255
- Director at Large - Franck Johannesen**  
email: [vikno11@verizon.net](mailto:vikno11@verizon.net)  
phone 941-323-4988
- Director at Large - Alan Levin**  
email: [Docal714@icloud.com](mailto:Docal714@icloud.com)



**Janet A. Collins at Advantage Lumber  
December 19, 2018.**

Janet is a 1996 graduate of the Cabinet and Furniture Making program at North Bennet Street School in Boston, MA. Upon graduating, she was hired for their position of Continuing Education Director. In 2003 she developed and implemented woodturning workshops there after securing a donation of a dozen lathes.

Her workshop teaching experience includes Anderson Ranch, North Bennet Street School, Dartmouth College, Vermont Woodworking School, Snow Farm Craft School, Wooden-Boat School, Connecticut Valley School of Woodworking and The Furniture Institute. Currently she teaches woodworking full time to students and faculty at the Dartmouth College Student Woodshop in Hanover, NH.

She has demonstrated woodturning at the 31st Annual American Association of Woodturning Symposium in Kansas City and the Granite State Woodturners New England Symposium. Her woodturning demonstrations include the Vermont Precision Museum, Guild of New Hampshire Woodworkers, Northern Vermont Woodturners, Upper Valley Woodturners, Twin State Woodturners and Carolina Mountain Woodturners.

Her furniture and woodturning have been exhibited at Guild of Vermont Furnitures Annual Exhibit, Vermont Woodworking Festival, Catamount Arts, Vermont Precision Museum and the Vermont Arts Council Open Studios.

In 2006, Janet was awarded the Furniture Maker of the Year by the Vermont Wood Manufacturing Association. In 2016 she was awarded the North Bennet Street School Distinguished Alumni Award.

Janet has written and published articles on woodworking in Fine Woodworking Magazine and WoodenBoat Magazine. She has three articles published in American Woodturner, Turn a Windsor Style Footstool, April 2016, Turn a Better Mallet, February 2017, and Inlay Techniques for Woodturners, April 2017.

Janet lives in Ryegate, VT. Her shop is located in the barn at her home where she continues to make furniture and turn wood. Her work can be seen on her website [www.greenmountainwoodturning.com](http://www.greenmountainwoodturning.com).

**Some details for the demo and workshop:**

The demo will briefly cover some inlay techniques and the turning of a bowl/platter that has already been inlaid.

The workshop will cover the inlay techniques more in depth. Participants will have the chance to apply the inlay on their own bowl/platter blank and if time permits they can turn the bowl during the workshop. I think the workshop can have ten participants if that many will fit in the space. I will be bringing the tools and inlay materials for the workshop but will need too have a drill press and band saw available. The bowl blank should be dried wood, cherry or walnut preferred, or another darker wood. It should be between 8 - 10 " diameter and about 2 inches thick. It should be milled so the surfaces are flat and parallel. I will attach a resource list for attendees to have, also the article I wrote for American Woodturner should be available for them as well. The article "Inlay Techniques for Woodturners" was in the April 2017 issue.

<http://www.greenmountainwoodturning.com>

**Saturday Pepper Mill Turning Class, November 10, 2018**



**Russ Fellows working with Steve Blitzstein.**



**Alan Levin working with Craig Spottswood.**



**Steve Johns working with Pat Sullivan.**



**Franck Johannesen working with Sheldon Crocker.**



**John Henry working with Johnny Weinbach.**



# Pepper Mill

It's a new grind  
By Nick Cook

I have never been much on projects that come in the form of kits—it just seems to be a little less creative than starting from scratch. But, the recent demand for custom pepper grinders has made the idea more intriguing.

Once you figure out the sequence of steps to make them efficiently, pepper mills are really not that difficult. I've found that the 10" mills are a nice size to work with and everyone seems to prefer it to larger or smaller ones. You can, of course, vary the shape widely from the basic mill I describe here.

Before you start turning, order your mechanism. I have tried many manufacturers, but Chef Specialties makes my favorite reliable stainless-steel mechanism. It also sells a polycarbonate salt mill, which prevents corrosion. (Packard Woodworks and Crafts Supplies sell these as "deluxe" mechanisms in the \$12 range.)

The following directions apply to the 10" Chef Specialties mill. Refer to the information sheet that is supplied with your mechanisms for specific requirements.

## Prepare your stock

To get at least two blanks from each strip, I make my slabs about 24" long. I also turn the mills from solid cherry and hard maple. I purchase 3" x 3" x 36" blanks from a local supplier. (You can find them on the Internet at [www.hardwoodweb.com](http://www.hardwoodweb.com).) The blanks for 10" mills—either laminated or solid—are cut to 12" lengths. This allows plenty of room for tenons at both ends and a parting cut to separate the top from the bottom.

For laminated pepper mills, glue up large slabs of a variety of 3" stock milled to random thicknesses. After the glue dries, make the first cut at a slight angle. Make the remaining cuts using the fence of either the tablesaw or a bandsaw. This is a technique I learned from Rude Osolnik when I assisted him in laminating and cutting of rolling pin blanks.

Locate and mark the center of each end of the blanks, then use an automatic centerpunch to make a dimple. Rough-turn the blanks to round cylinders with a tenon at each end. Size your tenon

*Continued*

to fit the jaws of your scroll chuck. In addition to the tenon at each end, make a parting cut to separate the base portion from the cap of the mill (Photo A). For ease of drilling from both ends, add a tenon to the top of the base section; this eliminates the need for a drill-bit extension.

Make the base section 8" long plus a  $\frac{3}{8}$ " tenon on each end; the cap will be approximately 2" long when completed.

### Drill routine

Once separated, mount the top of the base section in a scroll chuck with the bottom facing the tailstock. Drill the first recess in the bottom of the stock with a  $1\frac{5}{8}$ " Forstner bit in a Jacobs chuck. The recess should be approximately  $\frac{3}{8}$ " deep beyond the tenon. With a  $1\frac{1}{16}$ " bit, drill a second hole  $\frac{5}{8}$ " beyond the first recess.

To drill the bottom of the base, tighten the base top in your scroll chuck. Mount an extra long 1" bit in the chuck and drill as deep as possible in the base of the mill. You must go slowly (lathe speed of 500 to 700 rpm) and back the bit out frequently to remove the shaving and prevent overheating.

Remove the base section from the chuck and re-chuck it with the top facing the tailstock. Make sure the blank is centered and make a finishing cut across the top end of the base section. Complete the 1" hole through the base (Photo B). Remove the base from the chuck and set aside.

Mount the cap section in the chuck using the tenon on the top



end. Turn a 1" tenon approximately  $\frac{1}{2}$ " long on the bottom end of the cap, then make a finishing cut from the perimeter toward the tenon. The tenon will fit into the 1" through hole in the

base to align the two parts. It should fit without being too tight to turn freely. Next, drill a  $\frac{1}{8}$ " recess in the end of the tenon with a  $\frac{3}{4}$ " Forstner bit; this step makes it easier to center the turnplate.

Drill a  $1\frac{7}{64}$ " hole all the way through the cap of the mill.

The next step is to remove the cap from the chuck and mount a waste block (I prefer poplar) to turn a jam chuck. The jam chuck should be  $1\frac{5}{8}$ " diameter and about  $1\frac{1}{2}$ " long. Make a finishing cut across the end so the stock fits squarely against the recess in the bottom of the base of the mill.

Before mounting the mill on the jam chuck, test and size the mechanism. I press the spring bar into the recess, and then insert the two halves of the mechanism and the shaft through the base of the mill (Photo C). While holding the parts in place, place the cap on the top of the base and make a mark on the cap at the center of the threaded portion of the shaft. This marks the finished length. Now, remove the mechanism.

### Shape the mill

Depending on the final shape, you may wish to turn the cap and base separately. However, I find it faster and easier to turn the whole mill at once. Separate pieces require more turning time, but allow you better access for finishing the top of the cap.

Either way, cut off the tenon on the bottom end of the base. I do that with the mill mounted in the jam chuck with the cone center in the tailstock.

To turn them together, mount the base on the jam chuck, insert the tenon of the cap into the through hole of the base, and use a cone-shaped live center to hold the assembly together (Photo D).

To turn them separately, make a second jam chuck. This time, turn the chuck with a recess to fit the tenon on the bottom of the cap. Then press it into the chuck and turn to the desired shape.

### Final dashes

After shaping the mill, sand with 150-, 180- and then 220-grits. My favorite finish for most utilitarian items is urethane oil. You can apply it right on the lathe and build it up to a high-gloss finish. For a satin sheen (my preference), cut back the gloss with steel wool.

After the finish dries, assemble the mechanism. Attach the turnplate in the recess on the bottom of the cap. Press it in place, and drill  $\frac{3}{32}$ " drill pilot holes to prevent the screws from splitting the wood. Screw the turnplate to the cap and set it aside.

Turn the base upside down and insert the spring bar in the recess in the bottom. Press the female portion of the grinder mechanism into the spring bar. Slide the male portion of the grinder onto the shaft and then the spring bar, and slide the shaft through the female mechanism and the spring bar.

Place the retainer bar over the assembled mechanism, line up the holes, drill pilot holes, and screw in place. Slide the cap over the top end of the shaft and screw on the top knob. Finally, tighten the knob to adjust the grind.

Nick Cook (nickcook@earthlink.net) is an honorary lifetime AAW member. He lives in Marietta, GA, and is a production turner and frequent turning demonstrator.

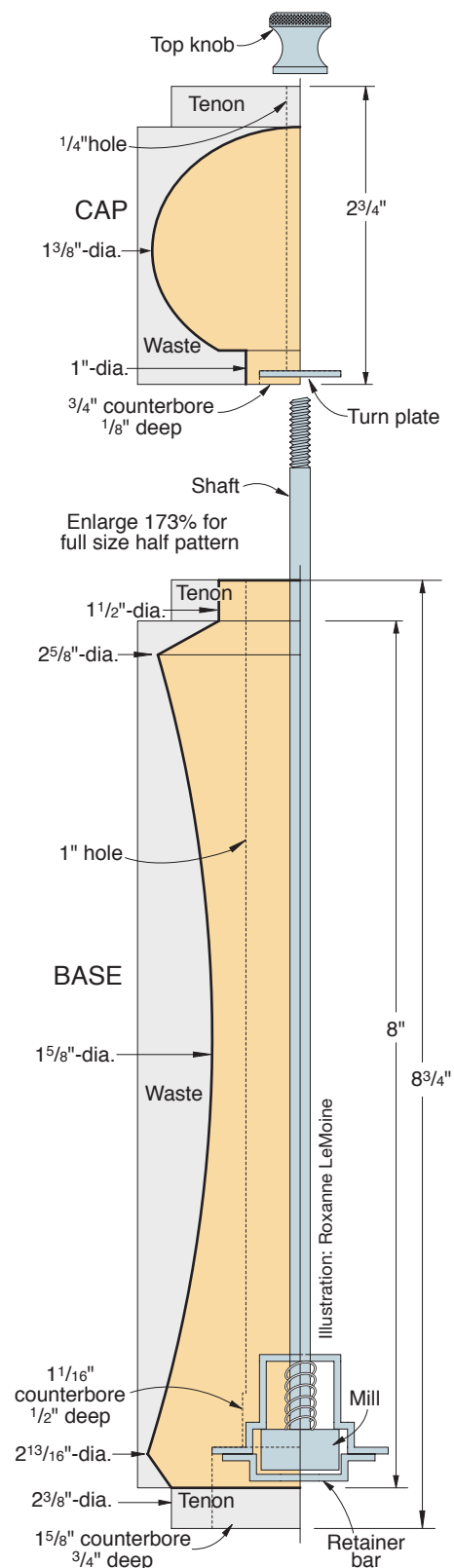



## Bill Clark's "Pearls & Ideas" Demo, November 13, 2018

Photos and text by David Senecal.



Given Bill's devotion to woodturning and his constant search for new ideas, he was asked to provide the audience with some new "pearls" or ideas that he had picked up as of late.

Bill began by saying that he sold a lot of bowls and other items over the course of a year at various craft shows and other venues. Since setting up and dismantling his booth took a lot of time and energy he was always looking for ways to pack and unpack his inventory of sale items as fast of possible and in such a manner as to take the least space possible during transportation. In this regard, he and his wife have taken to inserting the bowls in old T-shirts and stacking them together. This has proven to be much faster than wrapping them in bubble wrap or paper.

While on the subject of bowls he brought up a couple of interesting websites that offered short videos on the bowl making process. He mentioned Andrew Pierce Bowls in Vermont and the Holland Bowl Mill in Michigan. Another member also recommended the Great Alaskan Bowl Company as a great site to visit.

Bill then went on to talk about his use of resin to fill in imperfections. His preference was the West Resin system. He likes to first thicken the resin with corn starch and then mix in a "slow" hardener in order to have more time to apply the mix to the voids. With respect to coloring the resin, he had discovered a new source for buying metal powders at a fraction of the normal cost. While one had to purchase in larger quantities one can always split the order and the cost with fellow turners. The site was Metal Powders USA.



Bill then showed us a drill rod extension with revolving handle for his sanding disk setup that he now uses for sanding his bowls. He also buys rolls of 4" wide sticky back Velcro to use with the pads themselves.

In order to avoid marking his work during clamping or securing he now makes extensive use of weather stripping.

Finally, Bill showed us how he manages to center and secure large heavy bowl blanks to his lathe. He now sets a used inner tube from an electric golf cart on the ways of the lathe. The valve of the tube has been modified to allow it to be attached to his compressed air system and to be inflated and deflated with a control. Bill then sits the blank on the inner tube and simply inflates the tube until the blank rises to the desired height and is centered with the drive on the headstock.



**Sarasota Woodturner Members' Show & Tell, November 13, 2018**

*Photos by Russ Fellows*



## Russ Fellows' German "Ring Turning" Demo, November 20, 2018

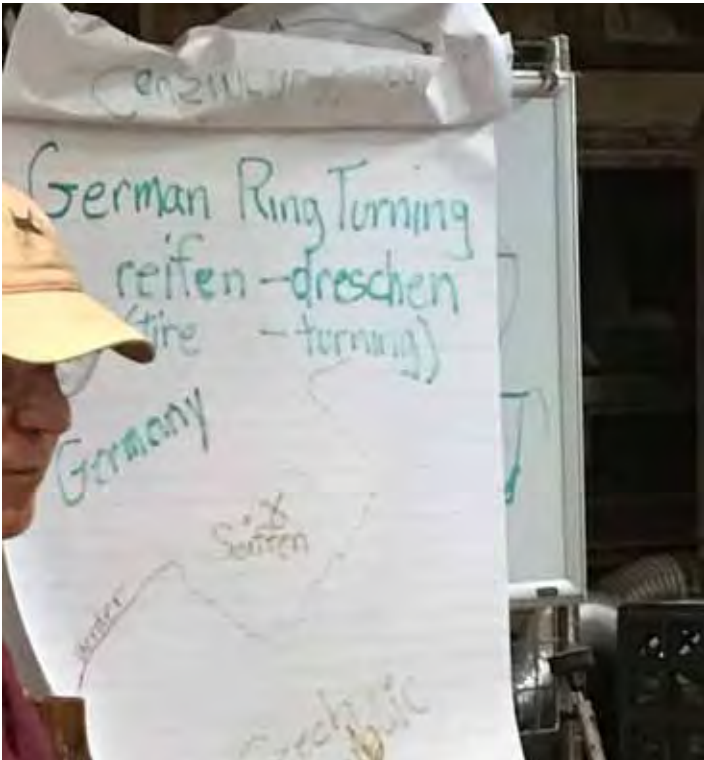

**Reifendrehen** is a unique type of toy manufacture using wood turning techniques that was developed in the **Ore Mountains** in the vicinity of the town of **Seiffen** and continues there to the present day. The process produces small animals and other figures or even little wooden houses in outline, that are used as toys or to decorate Christmas pyramids or Nativity scenes. The animals and figures (Reifentiere and Reifenfiguren) so produced are an inherent part of Ore Mountain folk art.

In the process known as Reifendrehen (literally "tyre turning") a suitable piece of wood, as far as possible free of splits, is worked on a special wood lathe to produce a wooden ring with a diameter of about 30 to 50 centimetres, the cross-section of which forms the outline of the desired figure. Small slices are then sawn off the ring. These are used as the raw material from which the finished figures are made by carving and painting.

The technique of Reifendrehen, which demands great experience and skill, emerged around 1800. It enabled, during the 19th century, the efficient mass production of wooden figures, because it was faster and cheaper than pure woodcarving by hand. Today part of the exhibition at the Ore Mountain Toy Museum in Seiffen is dedicated to the craft of the turners - the Reifendreher - who make these toys. In addition, there are several visitor workshops in the region around Seiffen.



The craft of wooden ring turning exists only in one place - in Seiffen and is only dominated by 8 craftsmen. **Christian Werner** is one of them. Wooden ring turning requires not only physical strength but also sense of form and high imagination. A trained wooden ringturner is able to produce a variety of animal character profiles and accessories with little technical effort.





H A P P Y   T H A N K S G I V I N G !

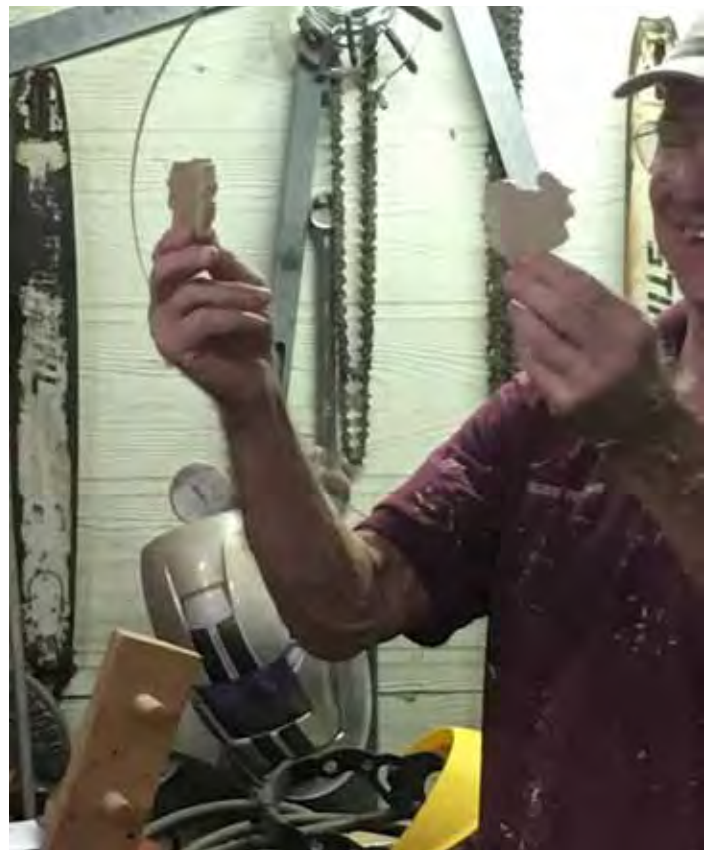

**Sarasota Woodturner Members' Show & Tell, November 20, 2018**



**Chet Orzech's lamp.**



**Alan Coppes' ornaments.**



**Franck Johannesen's Segmented bowl.**



**John Henry's Tiger Wood & Yellowheart bowl.**



**Alan Coppes' bowl.**



**Charley Bell's Segmented bowl.**



**Steve Johns' Camphor bowl.**



**William Clark's Rosewood bowl.**



**Alan Levin's White Pine bowl  
with coffee grounds filler.**



**Steve Johns' Maple bowl.**

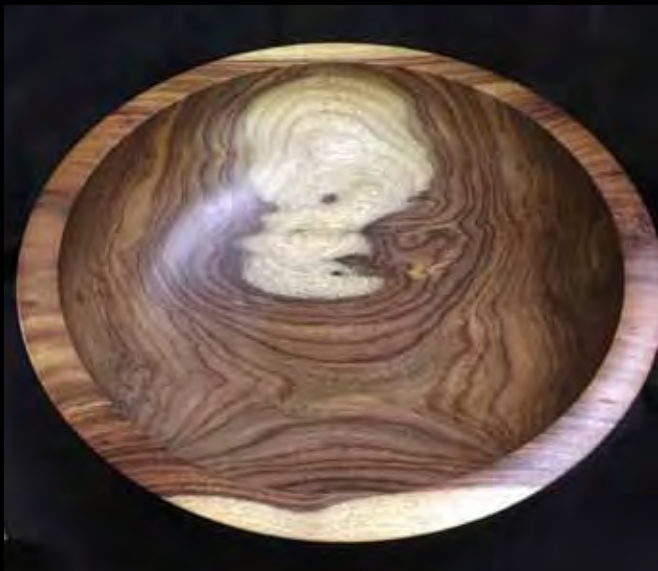

**Steve Johns' Rosewood bowl.**



**Alan Levin's bowl.**





**Dave Laubisch's ornaments.**



**Dave Hausmann's travel mugs.**



**Alan Levin's Flame Box Elder bowl.**



**Steve Johns' Eucalyptus bowl.**

**Franck Johannesen's Genie Bowl Hollowing Demo, November 27, 2018**



Carter & Son paring tool.



Use a French Curve to draw a continuous curve pattern.





Hollowing with 3/8" high speed cutting tool edge and reverse lathe speed direction.



Self feeding speed bore drill bit.



Unfortunately the glue did not hold the bottom piece in place when reversed in lathe for further shaping.

**Sarasota Woodturner Members' Show & Tell, November 27, 2018**



**Steve Johns' Segmented bowl.**



**Russ Fellows' Natural Edge bowl.**



**Steve Johns' Maple bowl.**



**Steve Johns' Zebra Wood pepper mills.**



**William Clark's Rosewood bowl.**



**Mike Gasco's Eucalyptus pepper mill.**



**William Huff's Norfolk Island Pine bowl.**



**Steve Johns' Maple bowl.**





**William Clark's** China Berry bowl with Black Liming Stain.



**William Clark's** China Berry bowl with White Liming Stain.



**Chet Orzech's** Indian Rosewood bowl.



**Norm Stabinski's** Multi-wood vessel.



**Russ Fellows' Bottle stoppers.**



**Russ Fellows' Natural Edge bowl.**

**Advantage Lumber Tool Exchange and Wood Sale, December 1, 2018**

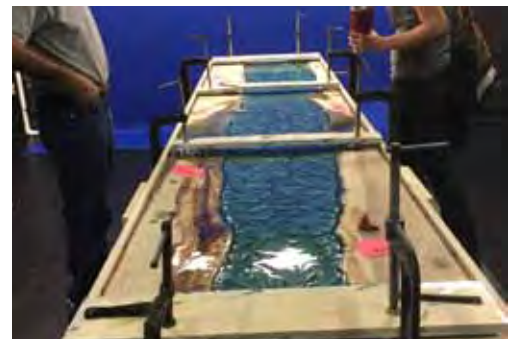



## Bowls of Hope at Ed Smith Stadium, December 2, 2018



The bowls of Hope was the most rewarding project of the year. We had made over 250 salad bowls for this organization which were overwhelmingly popular with public and volunteers. Plus a sample of the foods from the best restaurants in town.  
— Franck Johannesen



# Jim Weeks Bandsaw Discussion, December 4, 2018



**Jim Weeks** leading a lively discussion on bandsaws at Franck's studio with over 50 members in attendance.

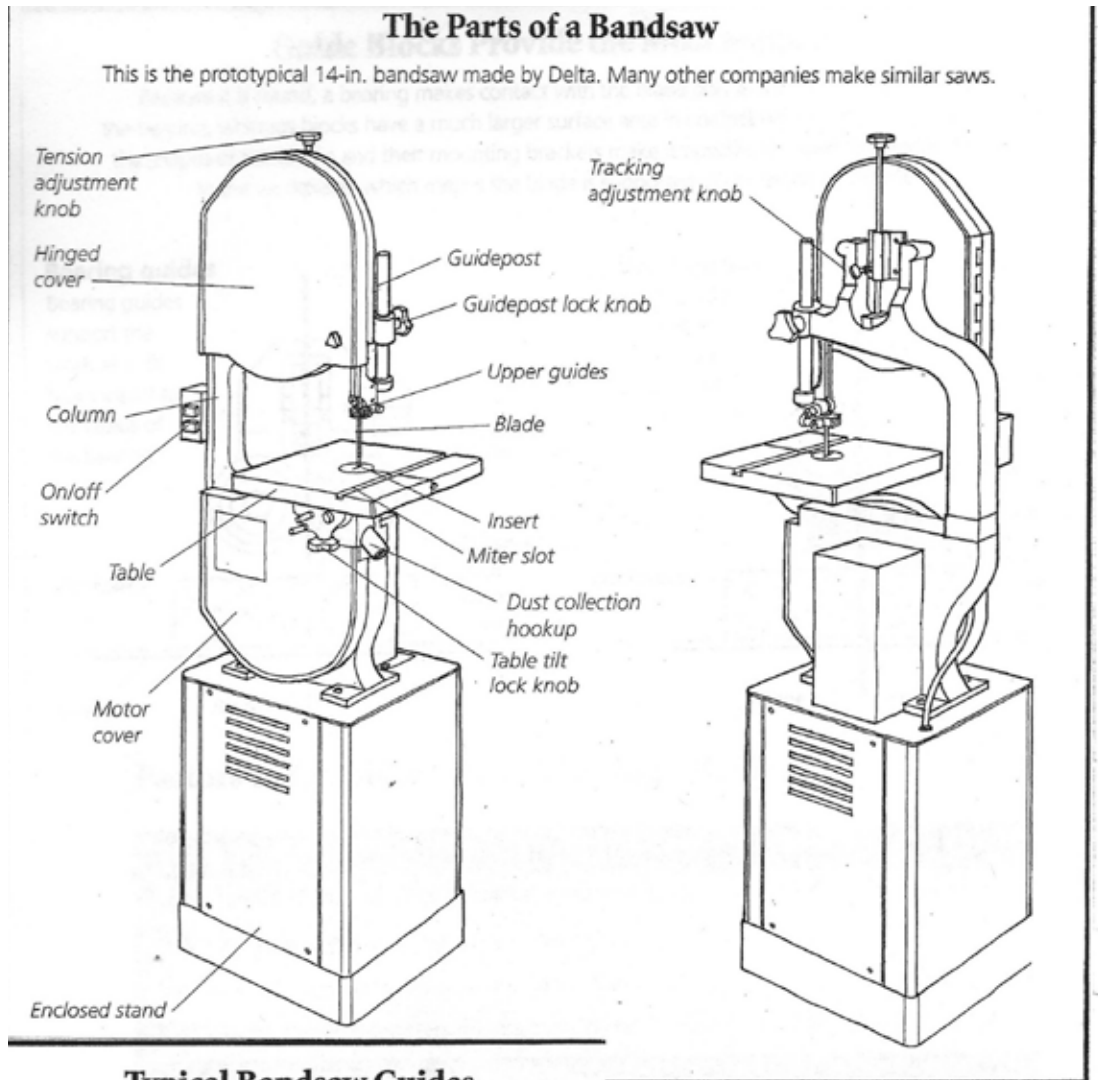

### Typical Bandsaw Guides

Guides support the blade to prevent both side-to-side and backward motion. This drawing shows guide blocks, which are standard equipment on most midsize bandsaws.

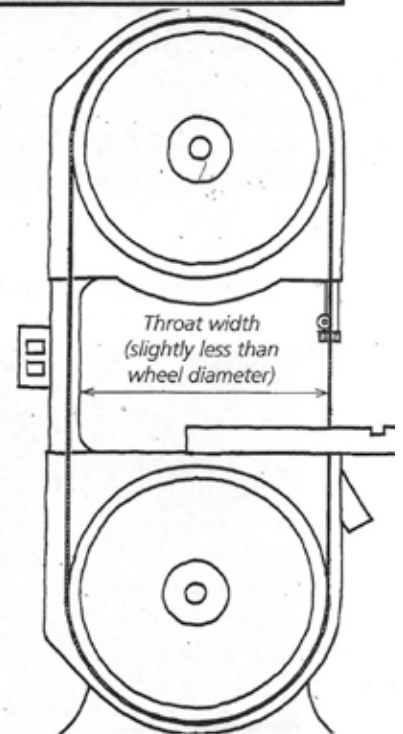
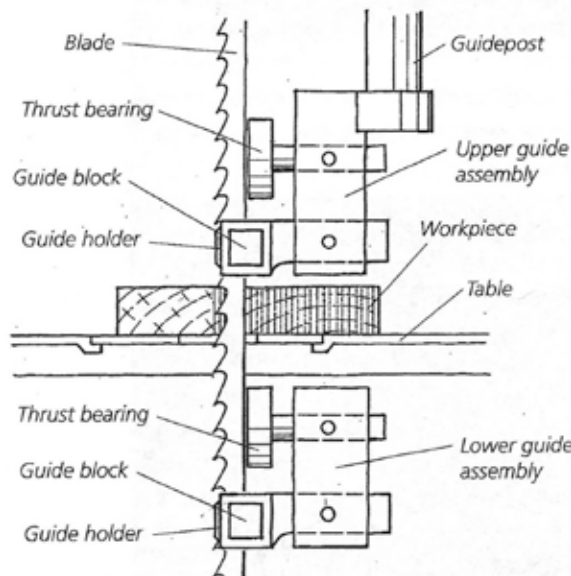

## Guide Blocks Provide the Most Support

Because it is round, a bearing makes contact with the blade only in a small area tangent to the bearing, whereas blocks have a much larger surface area in contact with the blade. In addition, the shapes of the blocks and their mounting brackets make it possible to lower the guides closer to the workpiece, which means the blade is supported closer to the actual cut.

### Bearing guides

Bearing guides support the work at a distance equal to the radius of the bearing.

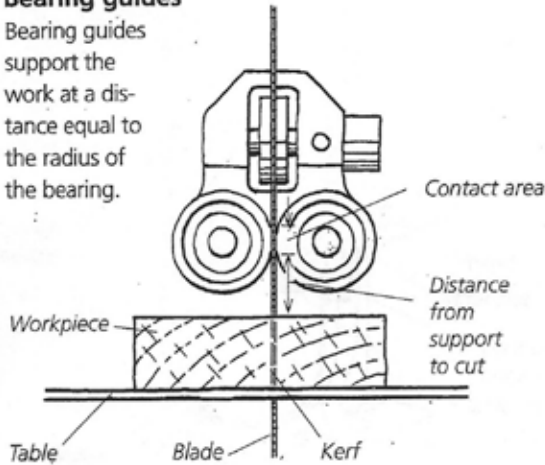

### Block guides

Block guides support the blade closer to the work.

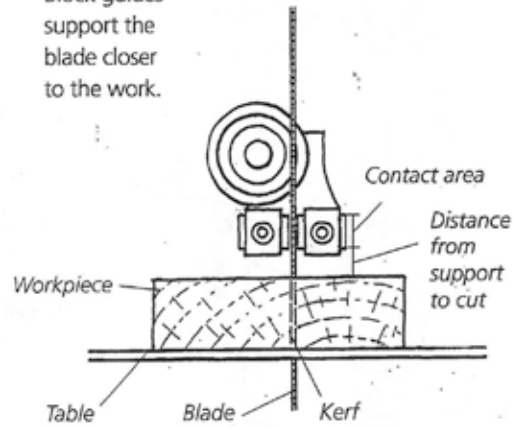

## Factors to Consider When Selecting a Blade

### Blade thickness

- Less than 0.025 in. to save material when resawing
- 0.025 in. for wheel diameters no less than 12 in.
- 0.032 in. for wheel diameters no less than 18 in.
- 0.035 in. for wheel diameters no less than 24 in.

### Tooth material

Carbon steel is inexpensive and readily available with a variety of characteristics.  
Use carbide for resawing; it has long blade life and gives the smoothest finished surface.  
Use bimetal for heavy ripping.

### Blade width

### Best use

- |   |   |
|---|---|
| $\frac{1}{16}$ in. to $\frac{1}{8}$ in. | Scrolling   |
| $\frac{3}{16}$ in. to $\frac{1}{2}$ in. | Cutting curves  |
| $\frac{3}{8}$ in. to 1 in. and above    | Resawing (base your selection on what your saw can tension) |

### Pitch

- |         |  |
|---------|--|
| 2/3 tpi | Resawing   |
| 3 tpi   | Resawing and ripping thick stock                                     |
| 4 tpi   | Ripping stock $\frac{1}{2}$ in. to 3 in. thick                       |
| 6 tpi   | General ripping and cutting curves in stock more than 1 in. thick    |
| 10 tpi  | Cutting curves in stock $\frac{1}{2}$ in. to 1 in. thick             |
| 14 tpi  | Cutting curves in stock $\frac{3}{8}$ in. to $\frac{1}{2}$ in. thick |
| 18 tpi  | Scrolling in stock $\frac{1}{2}$ in. to $\frac{3}{4}$ in. thick      |
| 24 tpi  | Scrolling in stock $\frac{1}{4}$ in. to $\frac{1}{2}$ in. thick      |

## How to Use a Bandsaw: Essential Bandsaw Tips & Tricks

[www.FamilyHandyman.com](http://www.FamilyHandyman.com)

Band saws come in many sizes and prices, but they're all basically the same tool: A band of steel with teeth rotates on two wheels and passes through a table. Guides and bearings located above and below the blade hold it in position as it cuts. You simply place a board on the table and push it through the rotating blade.

Entry-level benchtop saws offer portability over cutting capacity (maximum cutting width and height). Their lightweight construction is likely to allow some vibration, adjustments are finicky and blade choices are limited. Cutting thick hardwood can push them beyond their limits, but that's OK: These 9- and 10-in. saws are designed for light-duty use—they'll cut like the dickens when you don't ask them to do too much. And you can't beat the price.

Floor-model 14-in. band saws typically feature heavy construction with vibration-dampening cast-iron components, induction motors, substantial blade guides, tensioning and tracking systems and a full range of blade choices. They have larger cutting capacities than benchtop saws, and larger tables. Is the combination of capability and stability these saws offer worth the cost? If you're an avid woodworker, yes, especially if you want to try your hand at resawing.

### Cut on the Outside Edge of the Line

Band saw cuts usually leave saw marks, so it's good practice to allow extra material for smoothing the edge. Cutting on the outside edge of the line minimizes the amount of material you have to remove. However, accurately following the edge of a line—especially a curved line—takes practice. So until you've mastered this skill, it's best to start far enough away to leave a bit of wood showing between the line and the saw kerf. Remember: An oscillating spindle sander (or a sanding drum chucked in your drill press) is a band saw's best friend.

### Cut Nonferrous Metals

A blade with lots of fine teeth works great for cutting thin-walled brass, aluminum and copper. Make sure the teeth are hardened—a blade without hardened teeth will dull quickly.

### \$1 Blade Guide Setup

Use a dollar bill (or a piece of paper) as a spacer to properly set up a saw equipped with metal blade guides and thrust bearings. These metal components must be positioned ever so slightly away from the blade to minimize friction and keep it from overheating. Remove the blade guard to make these adjustments easier.



Start by setting the blade guide assembly about 1/4 in. above the height of the stock you're cutting. Then fold the bill into four thicknesses and use it to position the thrust bearing behind the blade (above left). Next, bring the guide assembly forward until the fronts of the guides (which are round bearings on this saw) rest just behind the bottoms of the blade's gullets (above center). Finally, use the unfolded bill to set the guides on both sides of the blade (above right). Then repeat the process to position the lower guides and thrust bearing.

### Immediately Replace a Dull Blade

This is a must-do. A slower feed rate, burning and increased difficulty in following a line are all signs of a dull blade. Persisting won't do any good—installing a sharp blade is the only solution.



*Tip:* Check the dull blade before you toss it. If it's dirty or covered with pitch from cutting resinous woods such as pine, a good cleaning may be all it needs. Just coil it and soak it in the same blade cleaner used for table saw blades.

### Release the Tension

Extend the life of your blades by releasing the tension whenever your saw will sit idle for three days or longer. Some saws have a quick-release mechanism that makes this a snap. Otherwise, rotating the tensioning knob two or three complete turns will do the trick.

Keeping the tension on can cause metal fatigue that will make the blade break prematurely. It can also

cause tracking problems by flattening the crowns on the saw's rubber tires.

### Upgrade the Blade

Our first recommendation is to replace the blade that came with your band saw. This simple upgrade is guaranteed to improve your saw's performance. We prefer blades made with hardened teeth that are cut rather than pressed (Timber Wolf is one brand). They cost more than twice as much as economy blades, but we still consider them a bargain.



Aside from quality, there are two features to consider in a blade:

**Width:** Wider blades are best for thicker wood and straight cuts because they 'wander' less than narrow blades. But narrow blades are essential for curves. The narrower the blade, the tighter it can turn. The narrowest blades can cut curves with a radius as small as 3/16 in. (That's the diameter of a ballpoint pen tip!)

**Teeth per inch:** Lower-TPI blades are better for cutting thicker stock. A higher-TPI blade will cut slower but leave a smoother surface. Although the widest and narrowest blades are good to have, you'll get the most bang for your buck with midsize blades. Ranging from 3/8 in. to 1/4 in. wide, midsize blades can make both straight and curved cuts. (A 3/8-in. blade has more rigidity for straight cuts; a 1/4-in. blade cuts a smaller radius, 5/8 in. vs. 1-1/2 in.) Installing one of these workhorses will minimize blade changing, because it'll make most of the cuts you typically make. If you make a lot of curved cuts, a 1/4-in. 6-TPI (teeth per inch) blade is the workhorse that you'll use the most.

If you want to slice thick boards into thinner boards, consider a 'resaw' blade designed just for that job. A resaw blade's added width provides rigidity to keep it from twisting. To cut without overheating, a resaw blade also has widely spaced teeth that cut aggressively and deep gullets that efficiently remove sawdust.

### Switch to Cool Blocks

The square steel guide blocks found on many older saws are bad news: They can cause a blade to overheat, and they'll quickly dull a blade if they come into contact with its teeth.



Replace these blade killers with Olson Cool Blocks. Cool Blocks are self-lubricating, so they won't cause overheating even if they contact the blade, and they're soft (compared with steel), so they won't damage its teeth. These two qualities also ease setup, especially with narrow blades (1/4 in. and smaller), because you can press Cool Blocks against the blade and its teeth. Unlike steel blocks, they don't have to be exactly positioned.

### Round the Blade to Improve Performance

Cut tighter curves, reduce blade vibration and increase blade life by truing the blade with a saw blade finishing stone. Start by removing the back corners, then round the back.



The process takes about five minutes, and the benefits last for a blade's lifetime. You can use the stone on scroll saw blades too.

### Set the Guides Close to the Wood

Every band saw manual tells you to set the guides close to the wood, and here are two good reasons why. It positions the upper blade guides as close as possible to the lower blade guides (which are mounted under the saw's table), so it provides the best cutting results. And it exposes less of the blade, which is safer for you.



*This article is reprinted from the internet.  
www.FamilHandyman.com*

**Sarasota Woodturner Members' Show & Tell, December 4, 2018**



**William Clark's Rosewood bowl.**



**W. J. Maroney's Natural Edge Oak bowl with feet.**



**John Henry's 4308 + Wipe-on Poly bowl.**



**Pepper Mill Shavings bowl.**



**Jim Weeks' Cocobolo threaded box.**

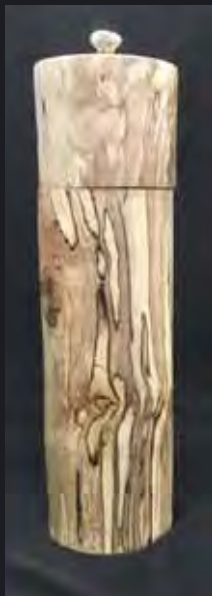

**Pat Sullivan's Pepper Mills.**



**Bill Foreman's ornament.**



**Norm Stabinsky's**  
Rosewood platter.



**Steve Johns' Cherry bowl.**



**Pat Sullivan's Apple Wood bowl.**



**Russ Fellows' Norfolk Island**  
Pine lamp.



**Jim Weeks' Poinciana vase with**  
Cherry screw top finial.

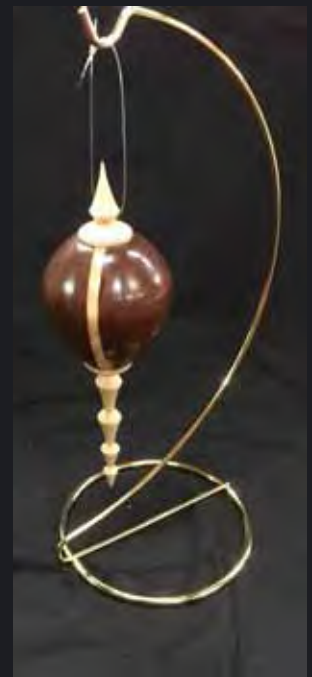

**Jim Weeks' Recycled**  
finial on stand.

**Saturday Pepper Mill Turning Class, December 8, 2018**



**Steve Johns working with his sister Carolyn Graf.**



**Franck Johannesen working with Bob Mandl.**

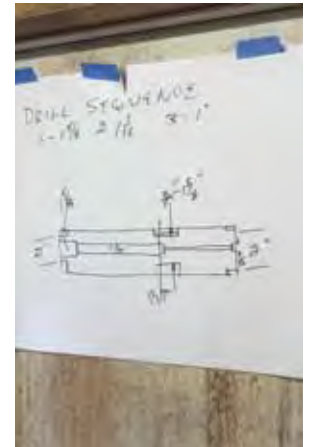

**Russ Fellows working with Tim Flow.**